

# Electrical Machines Laboratory-I

MANUAL

Electrical Engineering Dept. | EEN 2<sup>nd</sup> Year | 4<sup>th</sup> Semester | EE 292

Name of the Program: **B. Tech (EE), 2<sup>nd</sup> Year, 2<sup>nd</sup> Semester**

Course/Subject: **Electrical Machines Lab-I**

Course code: **EE 292**

*Electrical Machines Laboratory-I is very fundamental laboratory of Electrical Engineering Department. It is equipped with single-phase transformer, D.C. generator, D.C. motor and various electrical & electronics measuring instruments. The purpose of this lab is to give hands on experience on single-phase transformer, D.C. motor and D.C. generator. This laboratory is used for the undergraduate 2<sup>nd</sup> year 2<sup>nd</sup> semester students for course EE 292.*

### **The course outcomes:**

At the end of the course the student will be able to

1. Conduct different tests on single-phase transformer.
2. Connect and operate two single phase transformers in parallel.
3. Connect and control the speed of D.C. shunt motor using armature control and field control methods.
4. Obtain the characteristic of D.C. series motor.
5. Obtain the characteristic of D.C. shunt and D.C. compound generator.

### **Assessment Criteria:**

1. Regular attendance to classes.
2. Experimental result and lab report.
3. End semester final examinations.

## **ELECTRICAL MACHINES LAB-I**

### **List of the Experiments**

1. To perform polarity test on a single phase transformer
2. To perform Load test on a single phase transformer
3. To perform parallel operation on single phase transformers
4. No load test on a D.C. shunt Generator
5. Load test on a shunt D.C. Generator
6. Load Characteristic on D.C. compound generator
7. Speed control of D. C. shunt motor by- i) Armature voltage control method ii) Field current control method
8. Load test on D.C. series motor with mechanical load
9. To perform Swinburne's test on D.C. machine

## EXPERIMENT NO.:1

**To perform polarity test on a single phase transformer**

**OBJECT: To determine polarity of a single phase transformer.**

**APPARATUS REQUIRED:**

Sl. No.	Apparatus Required	Type	Range	Quantity

**NAME PLATE DETAILS:**

**CIRCUIT DIAGRAM:**

**Polarity test:**

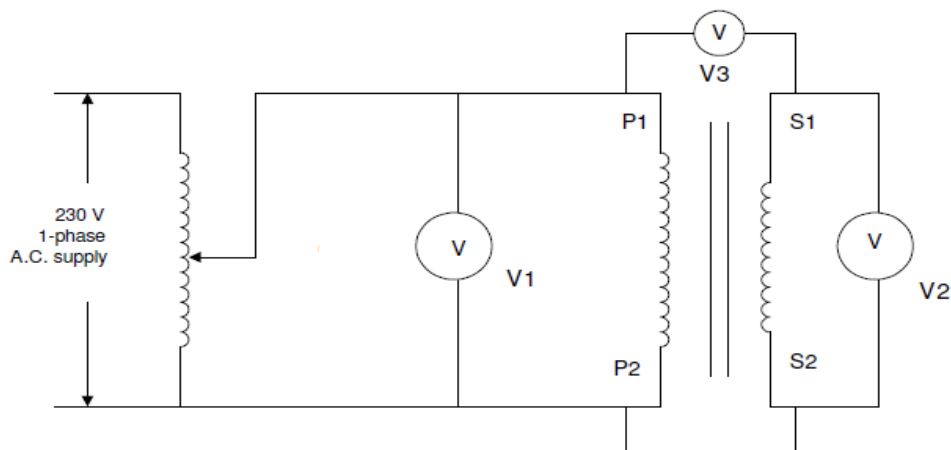

**Figure-1**

**PROCEDURE:**

**Polarity test:**

- 1) Make the connections as shown in Figure-1.
- 2) Connect the primary winding P1 – P2 to supply.
- 3) Short circuit the terminals P2 & S2.
- 4) Connect the voltmeters across primary & secondary windings of transformer.
- 5) Connect another voltmeter across P1 and S1.

- 5) Switch on the supply.
- 6) By varying the input voltage with the help of dimmerstat take various reading  $V_1$ ,  $V_2$  and  $V_3$  for various steps of input voltage.
- 7) Analyze the readings and decide about polarity marking of two windings of transformer.  
For this assume that a dot is present at terminal P1 of the primary winding.  
If  $V_3 = (V_1 + V_2)$ , the transformer has additive polarity and the other dot should be marked at S2.  
If  $V_3 = (V_1 - V_2)$ , the transformer has subtractive polarity and the other dot should be marked at S1.

**OBSERVATIONS:**

The given transformer is found to have \_\_\_\_\_ polarity. If a dot is marked at P1 on Primary side, the dot on secondary side should be at\_\_\_\_\_.

## EXPERIMENT NO.:2

### To perform Load test on a single phase transformer

**OBJECT:** To determine efficiency and regulation of a single phase transformer by direct loading.

#### APPARATUS REQUIRED:

Sl. No.	Apparatus Required	Type	Range	Quantity

#### NAME PLATE DETAILS:

#### CIRCUIT DIAGRAM:

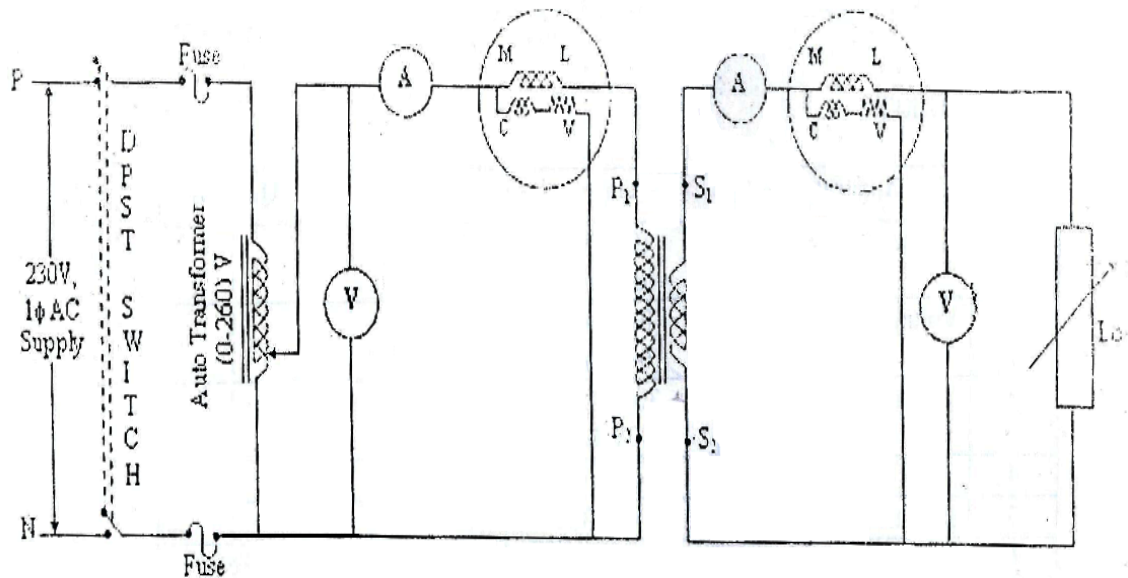

Figure-1

#### PROCEDURE:

1. Connect the circuit as shown in Figure-1.
2. Close the switch after checking the no-load condition and minimum position of auto-transformer.
3. Note down the reading of ammeters, voltmeters and wattmeters on both primary and secondary sides.
4. Open the switch.

**OBSERVATIONS:**

Sl. no.	Load	Primary		Secondary		Input Power $W_1$	Output Power $W_2$	Efficiency	Regulation
		$V_1$ (Volts)	$I_1$ (Amps)	$V_2$ (Volts)	$I_2$ (Amps)				

**Graph:** Plot the graph output power vs efficiency.

**Answer the following questions:**

1. What is the condition for max efficiency?
2. What is the condition for zero voltage regulation?

### EXPERIMENT NO.:3

**To perform parallel operation on single phase transformers**

**OBJECT:** To study parallel operation of single phase transformers.

**APPARATUS REQUIRED:**

Sl. No.	Apparatus Required	Type	Range	Quantity

**NAME PLATE DETAILS:**

**CIRCUIT DIAGRAM:**

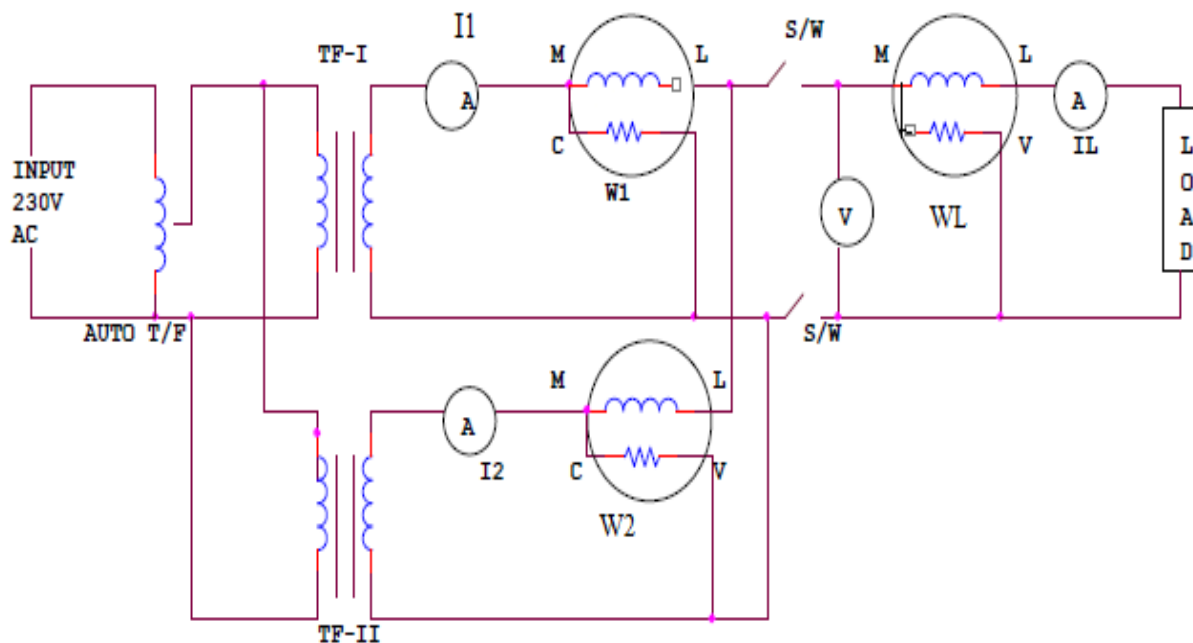

Figure-1

**PROCEDURE:**

1. Connect the circuit as shown in Figure-1.
2. Close the switch after checking the no-load condition.
3. Note down the readings of all ammeters and wattmeters for given load.



4. Repeat the above test for at least two different loads.

4. Open the switch.

**OBSERVATIONS:**

Sl. No.	$I_1$ (Amp.)	$I_2$ (Amp.)	$W_1$ (Watt.)	$W_2$ (Watt.)	$I_L=I_1+I_2$ (Amp.)	$W_L=W_1+W_2$ (Watt.)

**DISCUSSION:**

## EXPERIMENT NO.:4

### No load test on a D.C. shunt Generator

**OBJECT:**

To plot the open circuit characteristics (O.C.C.) of a D.C. shunt generator.

**APPARATUS REQUIRED:**

Sl. No.	Apparatus Required	Type	Range	Quantity

**NAME PLATE DETAILS:**

**CIRCUIT DIAGRAM:**

**Open Circuit Test:**

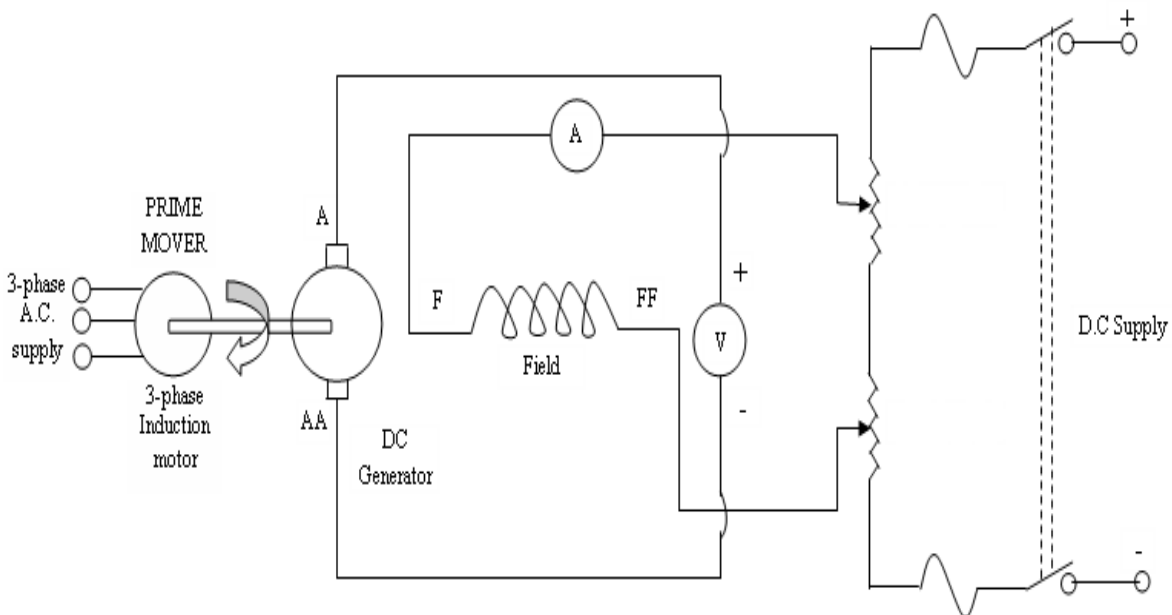

**Figure-1**

**PROCEDURE:**

1. Connect the circuit as shown in Figure 1.
2. Start the prime mover and run the generator at rated speed and no-load.
3. Record the voltage generated when  $I_f$  is zero.
4. Adjust the field current  $I_f$  only in an ascending direction and record the generated voltage  $V_a$ . Repeat until the generated voltage is rated voltage.
5. After reaching the maximum voltage generated, decrease the field current  $I_f$  in the same manner until 0mA is reached. At each  $I_f$ , measure and record the voltage  $V_a$ .

**OBSERVATIONS:**

**Open Circuit characteristics:**

Sl. No.	Induced E.M.F. (Volt.)	Increasing Field Current (Amp.)	Decreasing Field Current (Amp.)

**Graphs:**

1. Plot the curves between the generated voltage  $V_a$  and field current  $I_f$  both for ascending and descending currents.
2. Obtain the mean magnetization curve by using the above curves.

## EXPERIMENT NO.:5

### Load test on a shunt D.C. Generator

**OBJECT:**

To plot the external characteristics of a D.C. shunt generator by actually loading the generator.

**APPARATUS REQUIRED:**

Sl. No.	Apparatus Required	Type	Range	Quantity

**NAME PLATE DETAILS:**

**CIRCUIT DIAGRAM:**

**Load Test:**

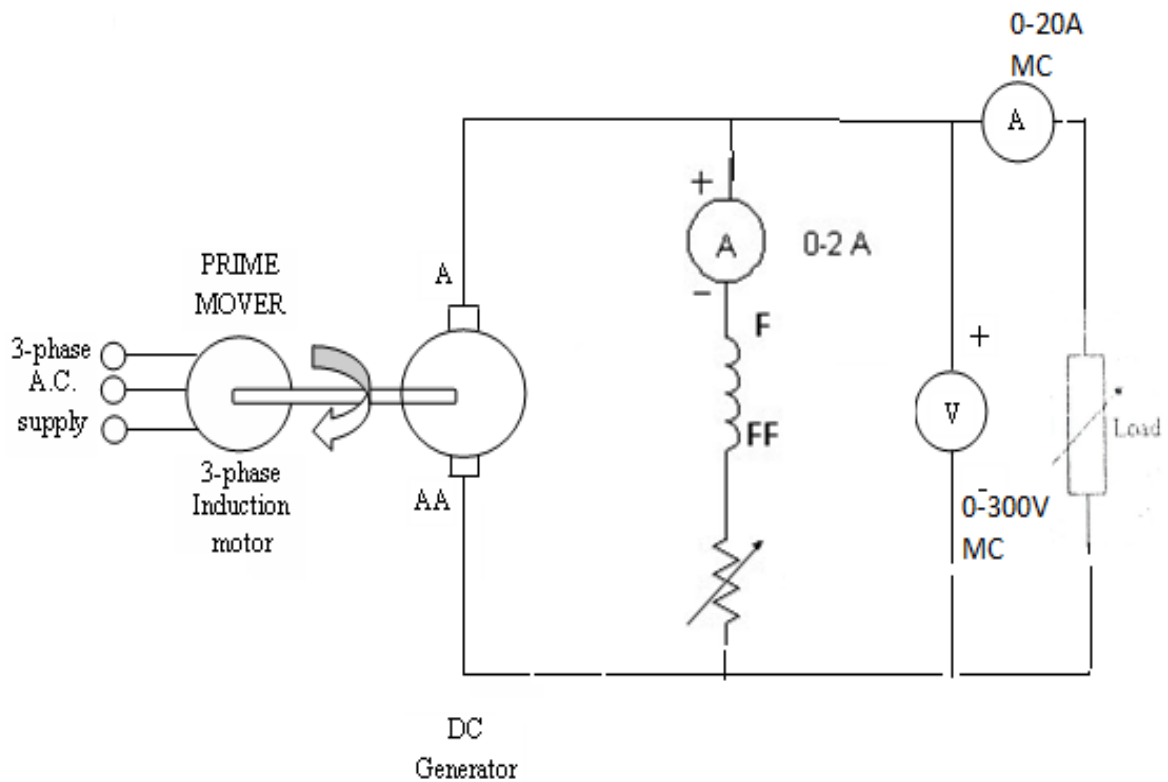

Figure-1

**PROCEDURE:**

1. Complete the circuit as shown in Figure-1.
2. Run the generator at no load and rated speed.
3. Under no load condition, note the ammeter and voltmeter readings, after bringing the voltage to rated voltage by adjusting the field rheostat of the generator.
4. Vary the load gradually and for each load, note the voltmeter and ammeter readings.
5. Unload the generator and after bringing the field rheostat to maximum position, open the switch.

**OBSERVATIONS:**

Sl. No.	Load current $I_L$ (A)	Terminal voltage $V_L$ (V)

**Graphs:**

Plot the external curve of the terminal voltage  $V_t$  against load current  $I_L$ .

## EXPERIMENT NO.:6

### Load Characteristics of DC Compound Generator

**OBJECT:** To obtain the load characteristics of DC Compound generator under cumulative and differential mode condition.

**APPARATUS REQUIRED:**

Sl. No.	Apparatus Required	Type	Range	Quantity

**NAME PLATE DETAILS:**

**CIRCUIT DIAGRAM:**

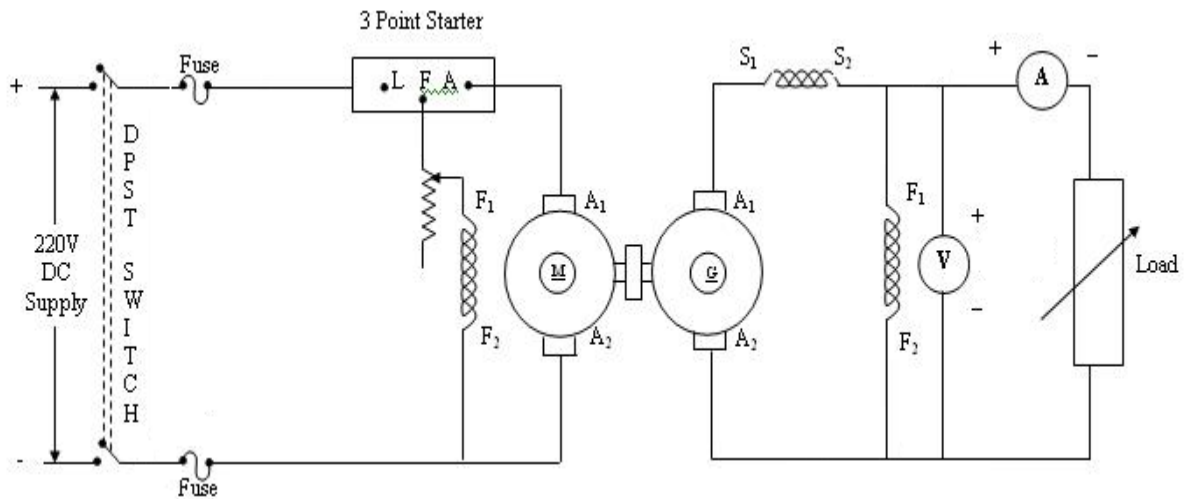

Figure-1

**PROCEDURE:**

1. Connections are made as per the circuit diagram.
2. After checking minimum position of DC shunt motor field rheostat and maximum position of DC shunt generator field rheostat, DPST switch is closed and starting resistance is gradually removed.
3. Under no load condition, Ammeter and Voltmeter readings are noted, after bringing the voltage to rated voltage by adjusting the field rheostat of generator.
4. Load is varied gradually and for each load, voltmeter and ammeter readings are noted.

- Then the generator is unloaded and the field rheostat of DC shunt generator is brought to maximum position and the field rheostat of DC shunt motor to minimum position, DPST switch is opened.
- The connections of series field windings are reversed the above steps are repeated.
- The values of voltage for the particular currents are compared and then the differential and cumulative compounded DC generator is concluded accordingly.

**OBSERVATIONS:**

S.No.	Cumulatively Compounded		Differentially Compounded	
	V (Volts)	I <sub>L</sub> (Amps)	V (Volts)	I <sub>L</sub> (Amps)

**Draw the characteristic curves.**

## EXPERIMENT NO.:7

### Speed control of D.C. shunt motor

**OBJECT:** To study speed control of a D.C. shunt motor

1. by varying field current with armature voltage kept constant
2. by varying armature voltage with field current kept constant

**APPARATUS REQUIRED:**

Sl. No.	Apparatus Required	Type	Range	Quantity

**NAME PLATE DETAILS:**

**CIRCUIT DIAGRAM:**

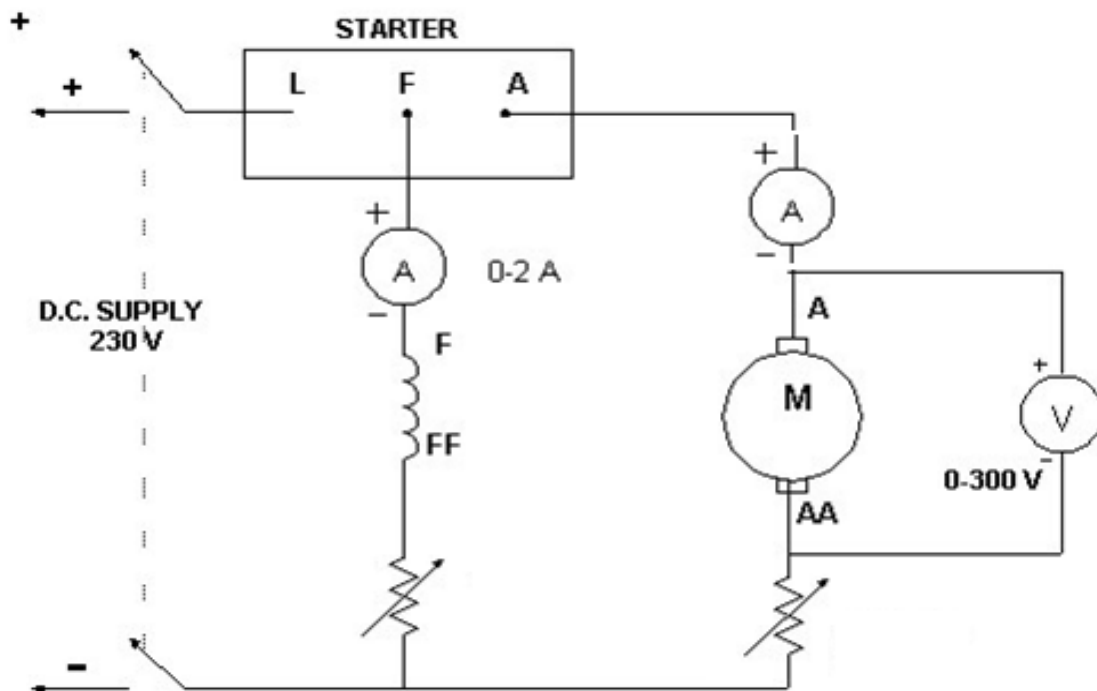

Figure-1

**PROCEDURE:**

- i) Connect the circuit as shown in Figure-1.
- ii) Start the motor with maximum resistance in the armature circuit and minimum resistance in the field circuit.



**iii) Armature Control**

Field current is fixed to various values and for each fixed value, by varying the armature rheostat, speed is noted for various voltages across the armature.

**Field Control:**

Armature voltage is fixed to various values and for each fixed value, by adjusting the field rheostat, speed is noted for various voltages across the armature.

iv) Bringing field rheostat to minimum position and armature rheostat to maximum position, switch is opened.

**OBSERVATIONS:**

**(i) Armature Voltage Control:**

Sl. No.	$I_{f1} =$		$I_{f2} =$	
	Armature Voltage $V_a$ (Volts.)	Speed N(r.p.m.)	Armature Voltage $V_a$ (Volts.)	Speed N(r.p.m.)

**(ii) Field Control:**

Sl. No.	$V_{a1} =$		$V_{a2} =$	
	Field Current $I_f$ (Amps.)	Speed N(r.p.m.)	Field Current $I_f$ (Amps.)	Speed N(r.p.m.)

**Graph:** Plot the following on separate graph papers.

- 1) N versus  $V_a$
- 2) N versus  $I_f$

**Answer the following questions:**

1. What are the limitations of armature voltage control and field current control methods?
2. What are the applications of dc shunt motor?

## EXPERIMENT NO.:8

### Load Test on D.C. Series Motor with Mechanical Load

#### OBJECT:

To perform load test on D.C. series motor.

#### APPARATUS REQUIRED:

Sl. No.	Apparatus Required	Type	Range	Quantity

#### NAME PLATE DETAILS:

#### CIRCUIT DIAGRAM:

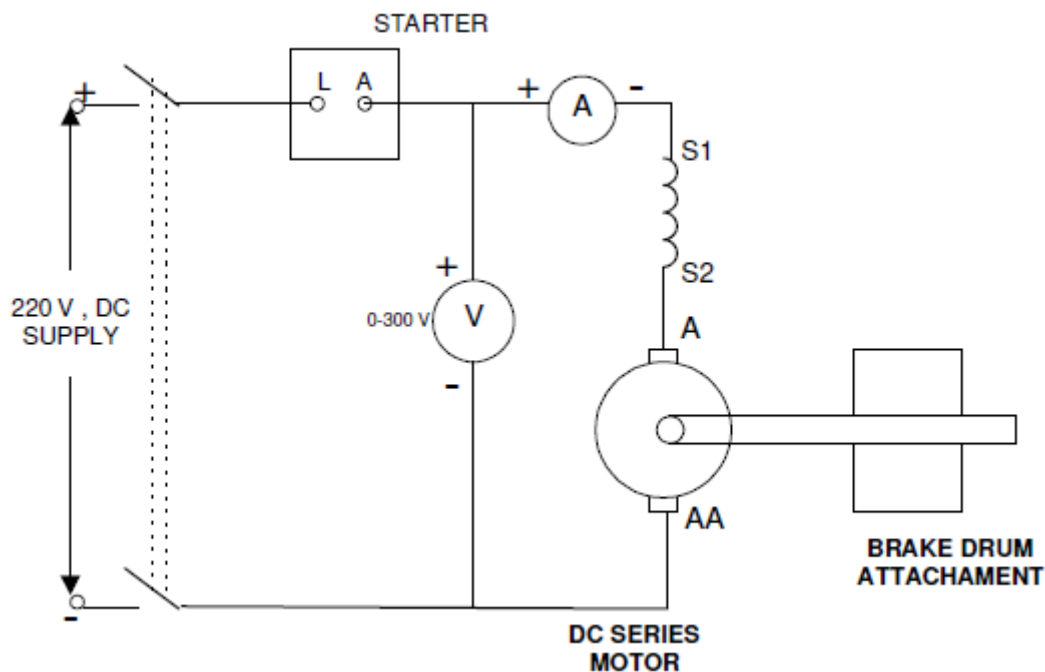

Figure-1

#### PROCEDURE:

- 1) Connect the circuit as shown in figure.
- 2) Keeping some load on the motor, start it with the help of starter.

- 3) At this load, note down the speed and also the forces in springs connected to brake drum.
- 4) Note voltmeter as well as ammeter reading.
- 5) Increase the mechanical load in steps by tightening the rope and note all the readings again.
- 6) Repeat step 5 till the rated current of motor is reached.
- 7) Calculate torque and efficiency of motor.

### Observation Table:

Radius of brake drum  $r =$

Sl. No.	$V_m$ (Volts)	$I_m$ (Amps)	$F_1$ (Kg.)	$F_2$ (Kg.)	N (rpm)

### Calculations:

Output torque  $T = [(F_1 - F_2) \times 9.81 \times r] N.m$

$$T = [(F_1 - F_2) \times 9.81 \times r] N.m$$

where  $r$  is radius of brake drum.

Output power  $P_o = \frac{2\pi NT}{60}$  Watt

Input power  $P_i = V_m \times I_m$

$$\% \text{ efficiency} = \frac{P_o}{P_i} \times 100$$

**Graph:** Plot speed Vs torque and output power Vs efficiency.

### Questions:

- 1) What is the significance of back e.m.f. in a d.c. motor?
- 2) Why is a d.c. series motor used to start heavy loads?

## EXPERIMENT NO.:9

### To perform Swinburne's test on D.C. machine

**OBJECT:** To perform Swinburne's test on the given D.C machine and predetermine the efficiency at any desired load both as motor and as generator.

**APPARATUS REQUIRED:**

Sl. No.	Apparatus Required	Type	Range	Quantity

**NAME PLATE DETAILS:**

**CIRCUIT DIAGRAM:**

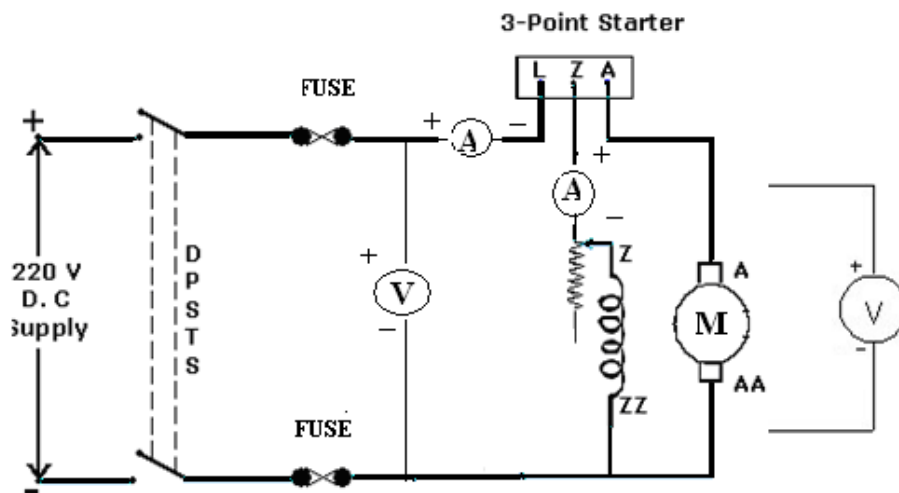

Figure-1

**CIRCUIT DIAGRAM TO FIND ARMATURE RESISTANCE:**

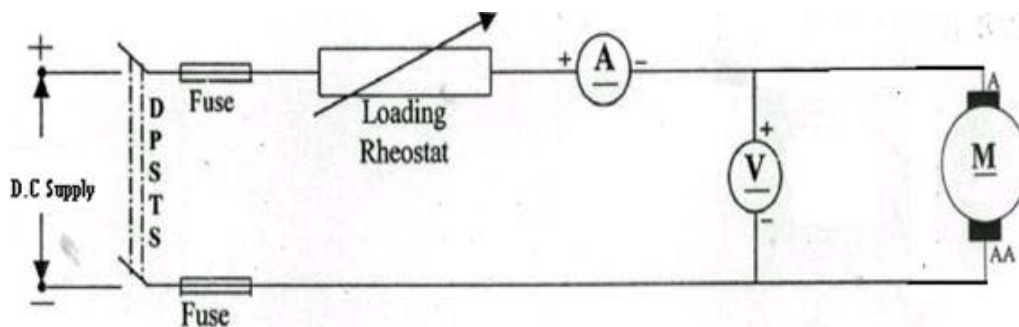

Figure-2

**PROCEDURE:**

- 1) Make all the connections are as per the circuit diagram.
- 2) Keep the field rheostat in **minimum** resistance position.
- 3) Excite the motor with **220V, DC** supply by closing the **DPST** switch and start the Motor by moving the handle of 3-point starter from **OFF** to **ON** position.
- 4) By adjusting the rheostat in motor field bring the speed of the motor to its rated value.  
 Note down the readings of Ammeter and Voltmeter at no load condition.

**TO FIND ARMATURE RESISTANCE (Ra):**

- 1) Connect the circuit per the circuit diagram
- 2) Keep the rheostat in maximum position.
- 3) Now excite the motor terminals by D.C. voltage by closing DPST switch.
- 4) Note down the readings of Ammeter and voltmeter.

**OBSERVATIONS:**

Sl. No.	Voltmeter reading $V_L(V)$	Ammeter reading $I_{L0}$ (A)	Ammeter reading $I_{sh}$ (A)	Speed in rpm

**ARMATURE RESISTANCE (Ra):**

Sl. No.	Current (A)	Voltage (V)

**CALCULATIONS:**

Constant losses ( $W_c$ ) = No load input – No load armature copper los  

$$= VI_{L0} - I_{ao}^2 R_a \quad (\text{where } R_a \text{ is the armature resistance )}$$
 and  $I_{ao} = I_L - I_{sh}$

**For motor:**

$$I_L = I_a + I_{sh}$$

$$\text{Input Power} = VI_L$$

$$\text{Cu losses} = I_a^2 R_a$$

$$\text{Total losses} = \text{No load losses or constant losses (} W_c \text{)} + \text{Cu losses}$$

$$\% \text{Efficiency } (\eta) = (\text{Output/Input}) * 100$$

$$\text{Output power} = \text{Input power} - \text{Total losses}$$

**For generator:**

$$I_a = I_L + I_{sh}$$

$$\text{Output Power} = VI_L$$

$$\text{Cu losses} = I_a^2 R_a$$

$$\text{Total losses} = \text{No load losses or constant losses (} W_c \text{)} + \text{cu losses}$$

$$\% \text{Efficiency } (\eta) = (\text{Output} / \text{Input}) * 100$$

$$\text{Output Power} = \text{Input Power} - \text{Total losses}$$

**CALCULATION TABLE:**

**As a Motor:**

Sl. No.	$I_L$ (A)	$I_a = I_L - I_{sh}$	$W = I_a^2 R_a$ watts	Total losses	%Efficiency

**As a Generator:**

Sl. No.	$I_L$ (A)	$I_a = I_L + I_{sh}$	$W = I_a^2 R_a$ watts	Total losses	%Efficiency

**Draw the efficiency vs. load current characteristic.**